

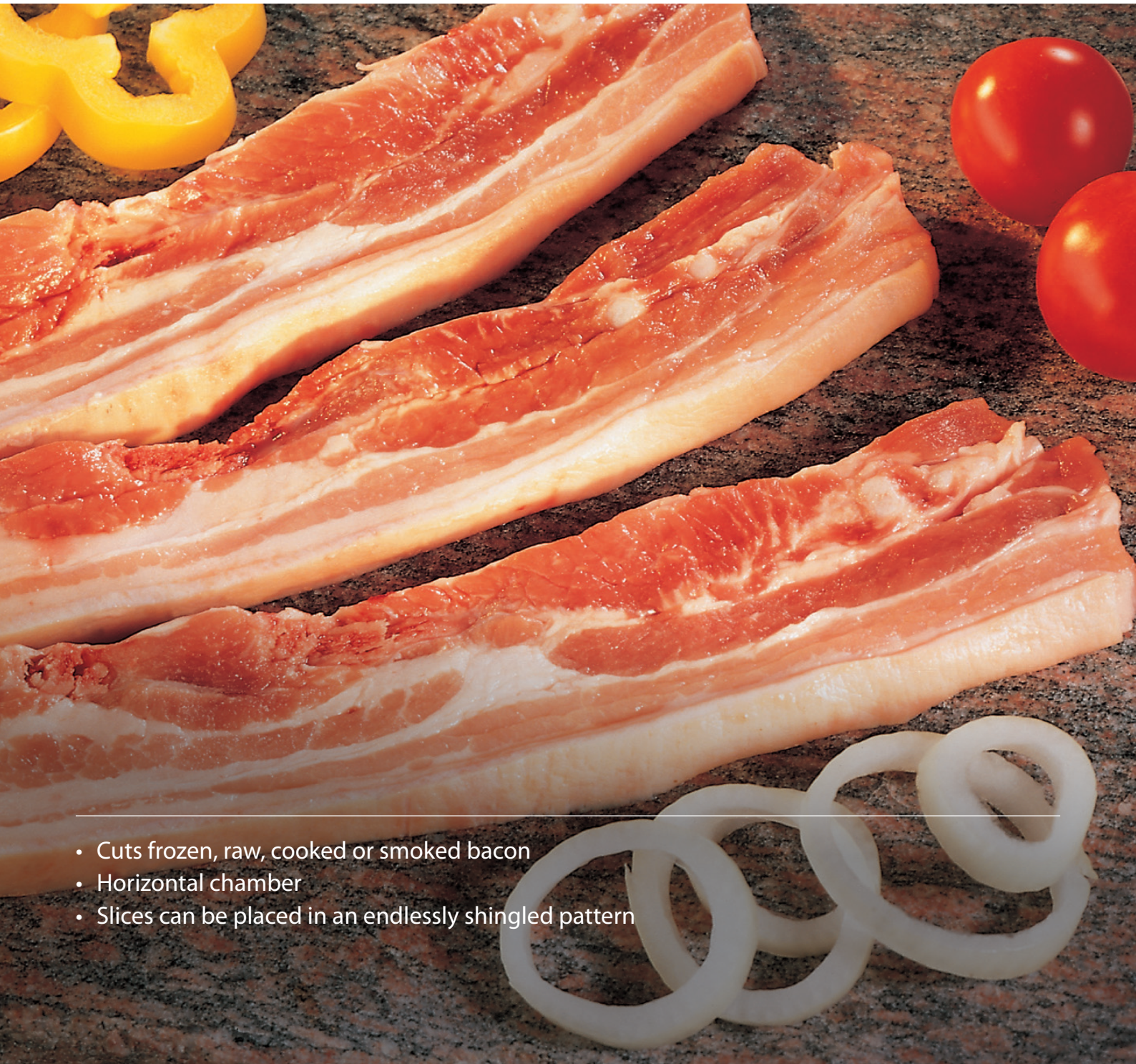

Your specialist for bacon and more

LION bacon



- Cuts frozen, raw, cooked or smoked bacon
- Horizontal chamber
- Slices can be placed in an endlessly shingled pattern

LION bacon

Portion cutting machine

A portion cutting machine that is named after what it is best suited for: the LION bacon.

Whether frozen, raw, cooked or smoked, with rind or without — this machine sets the bar when it comes to slicing bacon. Thanks to the fact that it was designed specifically for bacon, even two stacked products can be loaded into the spacious chamber and still be sliced with precision.



The horizontal chamber allows visu-ally attractive placement of the sliced product.



The slices can be placed continuously in an endlessly shingled pattern.



The LION bacon also processes frozen products, some even at very low tem-peratures (depending on product and application).



The gripper hook makes it possible to hold products that are up to 270 mm / 10 3/5".

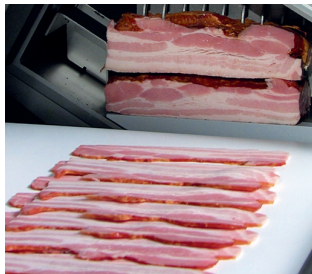

The machine is designed so that the products can also be stacked on top of each other and sliced.

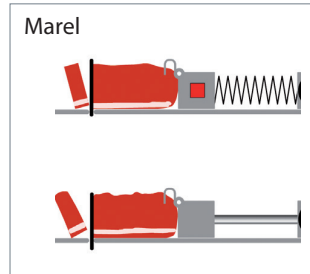

Marel

Precise cutting results and evenly thick slices: the Dynamic Feeding System (DVS) is standard. It allows syn-chronised slicing despite a continuous product feed. Without DVS wedge slices can be the result.

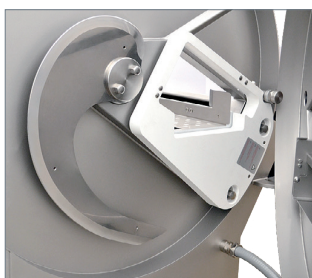

The blade operates at a speed of up to 300 revolutions/minute.

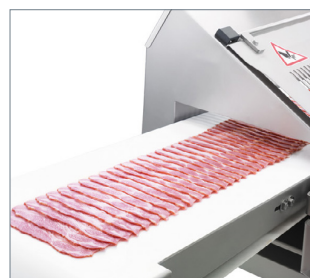

The slices can be either shingled continuously or arranged in shingled groups of e.g. ten slices.

Two models of LION bacon

LION bacon is available in the FB and EB models. The LION EB bacon model comes with an electronic control, which for example helps to keep the residual piece as small as possible.

TECHNICAL DATA	LION FB BACON	LION EB BACON
Max. cut-off length (mm/inch)	0.5–70; 1/50"-24/5"	0.5–250; 1/50"-94/5"
Max. cuts per minute	300	300
Cross-section of product w x h (mm/inch)	620; 24 2/5"	620; 24 2/5"
HOUSING DIMENSIONS		
Length/Width/Height (mm/inch)	2,690 / 1,150 1,550; 106" / 45 1/2" / 61"	2,690 / 1,150 1,550; 106" / 45 1/2" / 61"
Connecting load (kW)	3.3	3.4
Weight (kg/lb)	409; 902	409; 902
Product specific accessoires	on request	on request

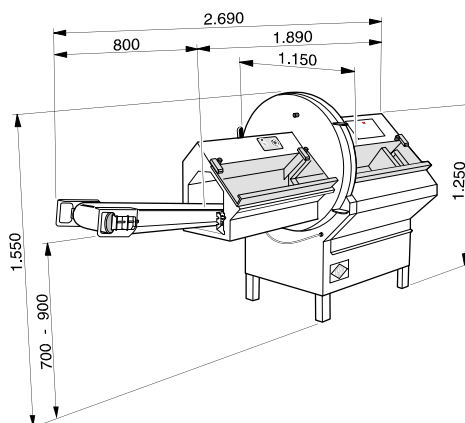
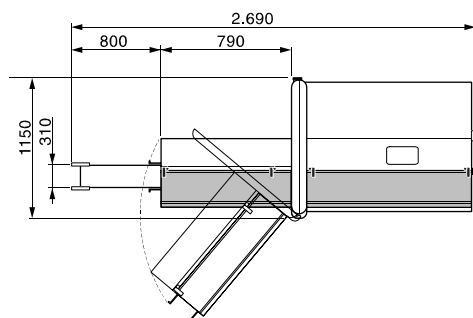

All measurements in mm.

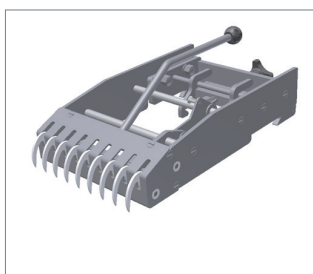

LION bacon gripper hook.

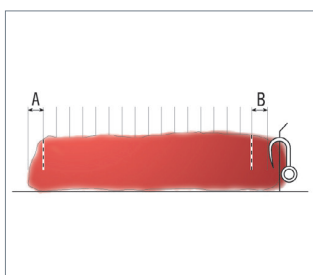

Residual product optimization ensures that the sliced product is cut into evenly thick slices to the residual piece, which remains as a complete slice.

Your benefits at a glance

- Visually attractive fanning of the bacon (smoked, salted pork belly)
- Continuously shingling and grouping (EB)
- Product holder is available single- or double-row, is optimally suited for bacon / pork belly applications (thin and wide)
- Back-feed path limitation (as a standard feature) for optimised processing even of short products
- Easy cleaning of the machine
- Available with conveyor belt

TRANSFORMING FOOD PROCESSING

